

PRODUCT No. 4433

Metal container for swivel forks – 1100 L



(Illustrative photograph)

Technical data

Material	Steel sheet
Capacity	1100 l
Weight	106,5 kg
Load capacity	500 kg
Skid distance	525 mm
Pouch dimensions	175 x 80 mm
Width	1200 mm
Depth	1000 mm
Height	950 mm

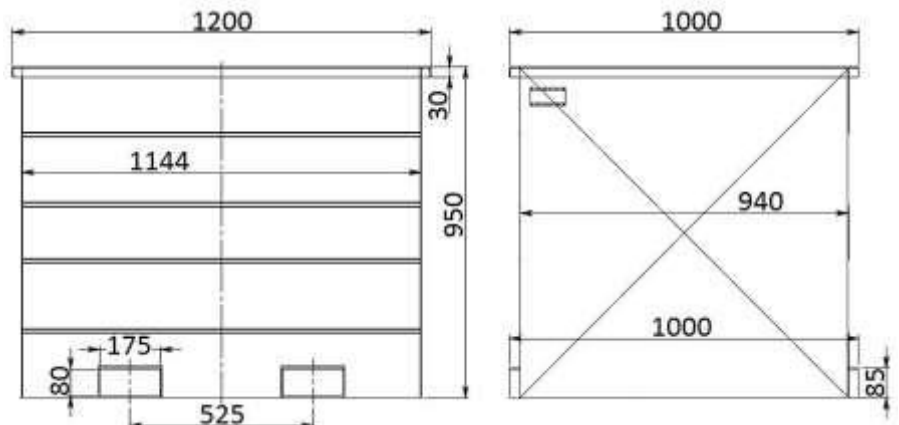

Attributes

- Made of high quality steel sheet.
- Equipped with an integrated adapter for manipulation by fork-lift machinery.
- Emptying of the container can be done by means of the forks with swivel mechanism on fork-lift machinery.
- Suitable for storage and transportation of raw materials, semi-finished products or municipal and separated waste.
- Stack only if the containers are empty (stack of 3 pcs). It is not possible to manipulate with container when stacking.

Color variations

- Standardly blue.

Product purpose

- Designed for manipulation with waste/material by fork-lift machinery.

Additions

- Do not exceed the technical specifications on the label.